

NOTES:

1. 5/8" ϕ MOUNTING HARDWARE IS RECOMMENDED.
2. MOUNTS THE BUTTERFLY MX 7 INCH SURFACE MOUNT UNIT.
3. COATED IN 2 MILS OF ZINC ENRICHED PRIMER AND 2-4 MILS OF COLOR MATCHED POWDER COAT.

UNLESS OTHERWISE SPECIFIED:

INTERPRET GEOMETRIC TOLERANCING PER: ASME Y14.5 -2009

DIMENSIONS ARE IN INCHES

TOLERANCES:
 FRACTIONAL $\pm 1/32$
 ANGULAR: $\pm 2^\circ$
 TWO PLACE DECIMAL ± 0.010
 THREE PLACE DECIMAL ± 0.005

SIZE

A

PART NO.

33PED-BUT-002-CRS

REV

0

NO SCALE

SHEET 1 OF 6

ITEM NO.	PART NUMBER	DESCRIPTION	QTY.
1	33PED-BUT-002-CRS	3X3 STEEL TUBE	
2	BACK PLATE 7S	7 INCH BMX BACK PLATE	
3	FACE PLATE 7S	7 INCH BMX FACE PLATE	
4	BASE PLATE 8 281	8" STANDARD BASE PLATE	
5	COVER PLATE 8 3125	8" STANDARD COVER PLATE	
6	KEYHOLE STUD	8MM KEYHOLE STUD	3

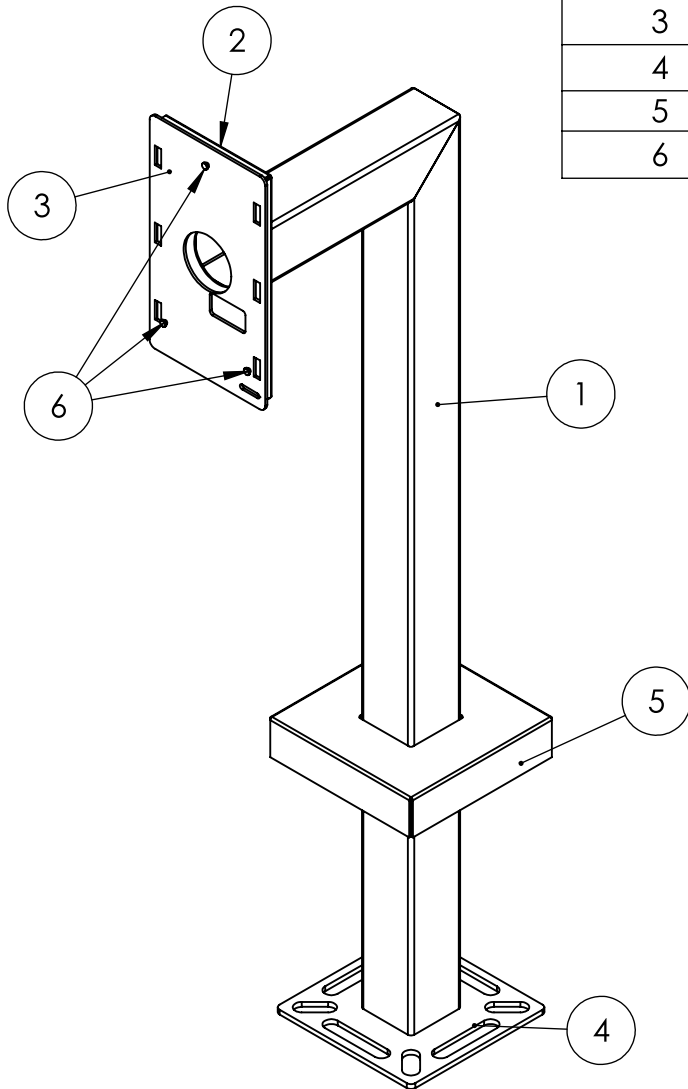

NOTES:

1. BUTT WELDED SECTIONS ARE NOT ALLOWED, EACH SECTION OF TUBE MUST BE FROM CONTINUOUS STOCK.
2. ALL WELDS ARE TO BE CONTINUOUS FILLET WELDS UNLESS NOTED OTHERWISE.
3. SEE STANDARD PREPARATION AND COATING INSTRUCTIONS FOR COATING PROCEDURE AND COLOR.
4. FASTENERS ARE TO BE BAGGED AND SHIPPED WITH PEDESTAL.
5. SEE STANDARD PACKAGING INSTRUCTIONS FOR PACKAGING PROCEDURE.

UNLESS OTHERWISE SPECIFIED: INTERPRET GEOMETRIC TOLERANCING PER: ASME Y14.5 -2009	DIMENSIONS ARE IN INCHES TOLERANCES: FRACTIONAL $\pm 1/32$ ANGULAR: $\pm 2^\circ$ TWO PLACE DECIMAL ± 0.010 THREE PLACE DECIMAL ± 0.005	SIZE	PART NO.	REV
		A	33PED-BUT-002-CRS	0
NO SCALE			SHEET 2 OF 6	