

NOTES:

1. 5/8"  $\phi$  MOUNTING HARDWARE IS RECOMMENDED.
2. MOUNTS THE BUTTERFLY MX 12 INCH SURFACE MOUNT UNIT.
3. COATED IN 2 MILS OF ZINC ENRICHED PRIMER AND 2-4 MILS OF COLOR MATCHED POWDER COAT.

|   |  |          |                   |          |
|---|--|----------|-------------------|----------|
| UNLESS OTHERWISE SPECIFIED:<br>INTERPRET GEOMETRIC TOLERANCING PER:<br>ASME Y14.5 -2009 | DIMENSIONS ARE IN INCHES<br>TOLERANCES:<br>FRACTIONAL $\pm 1/32$<br>ANGULAR: $\pm 2^\circ$<br>TWO PLACE DECIMAL $\pm 0.010$<br>THREE PLACE DECIMAL $\pm 0.005$ | SIZE     | PART NO.          | REV      |
|   |  | <b>A</b> | 33PED-BUT-004-CRS | <b>0</b> |
| NO SCALE  |  |          | SHEET 1 OF 6      |          |

| ITEM NO. | PART NUMBER        | DESCRIPTION             | QTY. |
|----------|--------------------|-------------------------|------|
| 1        | 33PED-BUT-004-CRS  | 3X3 STEEL TUBE          | 1    |
| 2        | FACE PLATE 12S     | 12 INCH BMX FACE PLATE  | 1    |
| 3        | BACK PLATE 12S     | 12 INCH BMX BACK PLATE  | 1    |
| 4        | BASE PLATE 8 281   | 8" STANDARD BASE PLATE  | 1    |
| 5        | COVER PLATE 8 3125 | 8" STANDARD COVER PLATE | 1    |
| 6        | KEYHOLE STUD       | 8MM KEYHOLE STUD        | 4    |

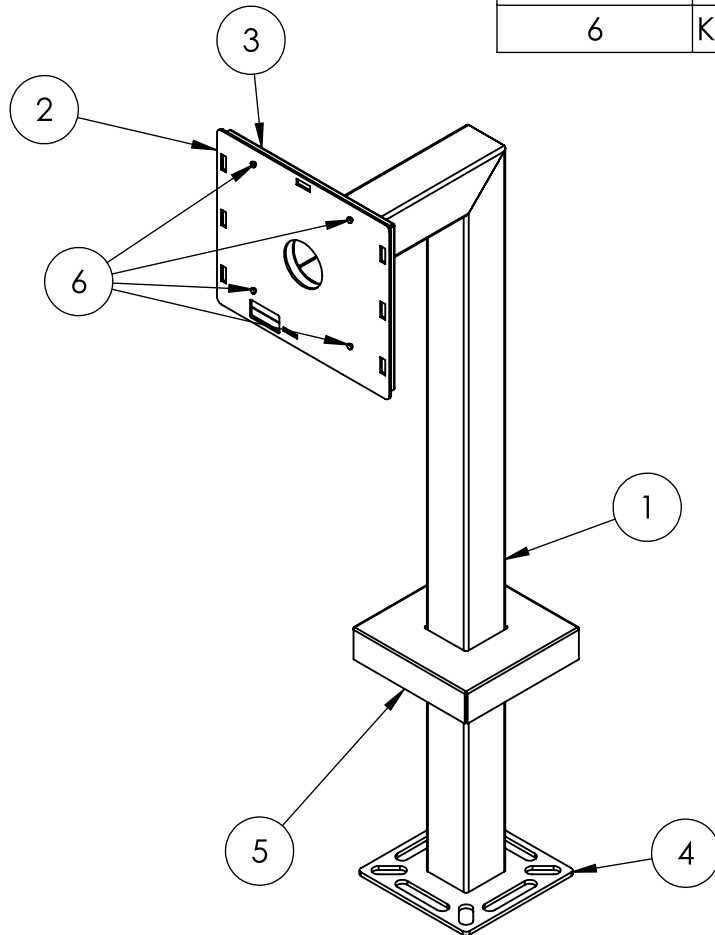

NOTES:

1. BUTT WELDED SECTIONS ARE NOT ALLOWED, EACH SECTION OF TUBE MUST BE FROM CONTINUOUS STOCK.
2. ALL WELDS ARE TO BE CONTINUOUS FILLET WELDS UNLESS NOTED OTHERWISE.
3. SEE STANDARD PREPARATION AND COATING INSTRUCTIONS FOR COATING PROCEDURE AND COLOR.
4. FASTENERS ARE TO BE BAGGED AND SHIPPED WITH PEDESTAL.
5. SEE STANDARD PACKAGING INSTRUCTIONS FOR PACKAGING PROCEDURE.

UNLESS OTHERWISE SPECIFIED:

INTERPRET GEOMETRIC TOLERANCING PER: ASME Y14.5 -2009

DIMENSIONS ARE IN INCHES  
TOLERANCES:  
FRACTIONAL  $\pm 1/32$   
ANGULAR:  $\pm 2^\circ$   
TWO PLACE DECIMAL  $\pm 0.010$   
THREE PLACE DECIMAL  $\pm 0.005$

SIZE  
**A**

PART NO.  
33PED-BUT-004-CRS

REV  
**0**